

HD 14 C

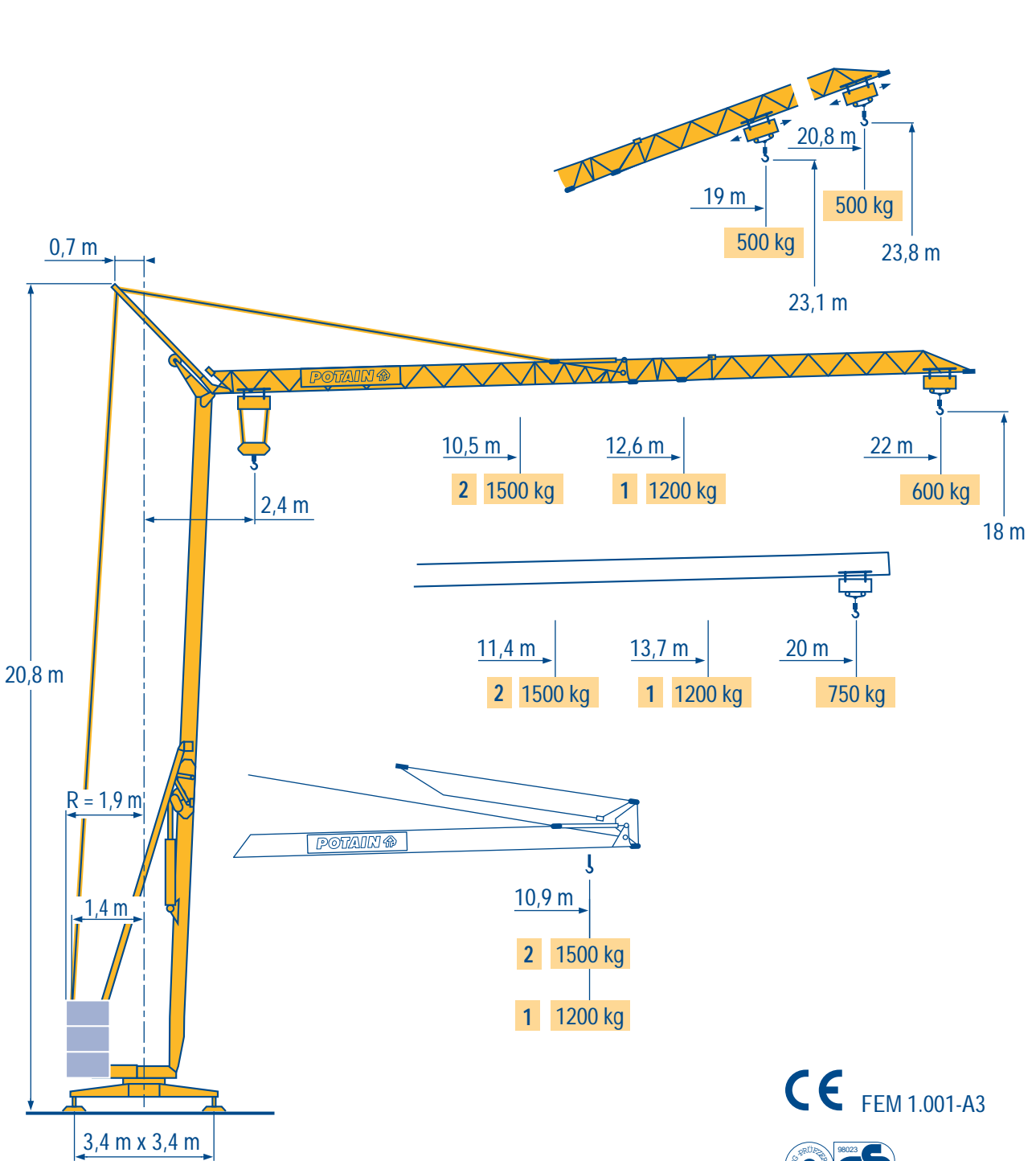

- HD
- HDT
- GTMR
- CITY CRANE
- TOPKIT MD
- MR
- MAXI MD
- MAXI TOPKIT

CE FEM 1.001-A3



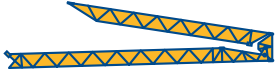

1 1200 kg

22 m 2,4 ▶ 10,9 m
1200 kg

12,6 13 14 15 16 17 18 19 20 21 22 m
1200 1155 1055 970 895 830 770 720 675 635 600 kg

20 m 2,4 ▶ 10,9 m
1200 kg

13,7 14 15 16 17 18 19 20 m
1200 1165 1070 990 915 855 800 750 kg

2 1500 kg

22 m 2,4 ▶ 10,9 m
1500 kg

10,5 11 12 13 14 15 16 17 18 19 20 21 22 m
1500 1420 1275 1155 1055 970 895 830 770 720 675 635 600 kg

20 m 2,4 ▶ 10,9 m
1500 kg

11,4 12 13 14 15 16 17 18 19 20 m
1500 1405 1275 1165 1070 990 915 855 800 750 kg

LMM 1

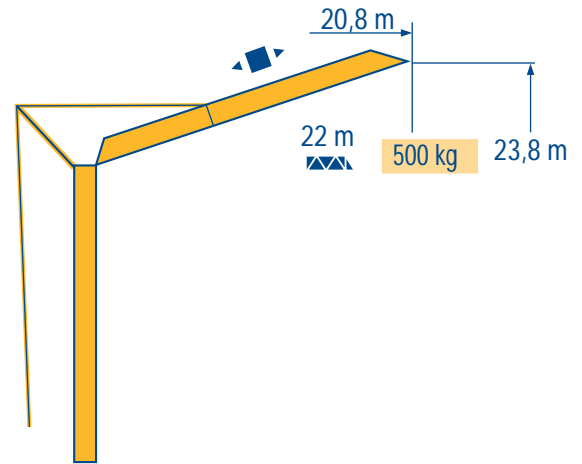
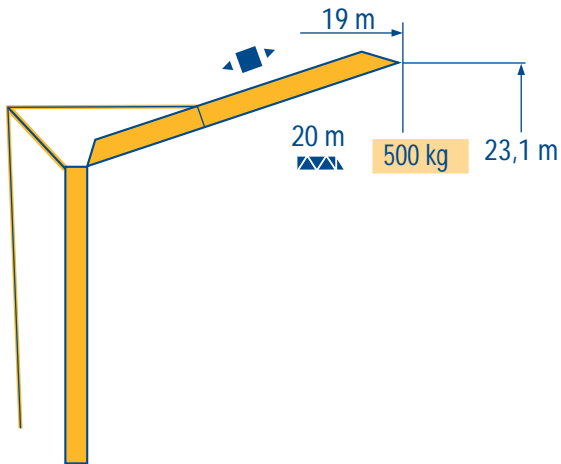

LMM 1



Chariot distributeur

Traversing trolley

Carrellino distributore



Verfahrbare Laufkatze

Carro distribuidor

变幅小车

Réactions
Eckdrücke

Reactions
Reacciones

Reazioni
反力

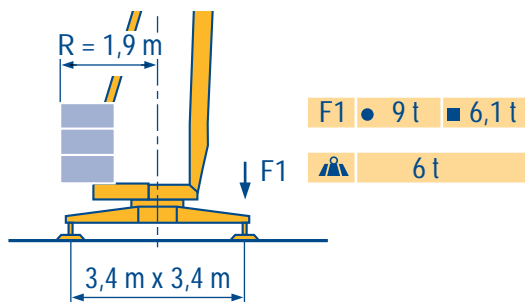

LMM 1

<ul style="list-style-type: none"> ● Réactions en service ■ Réactions hors service ▲ A vide sans lest ni train de transport avec flèche et hauteur maximum 	F	<ul style="list-style-type: none"> ● Reactions in service ■ Reactions out of service ▲ Without load, ballast or transport axles, with maximum jib and maximum height. 	GB	<ul style="list-style-type: none"> ● Reazioni in servizio ■ Reazioni fuori servizio ▲ A vuoto, senza zavorra ne assali di trasporto con braccio massimo e altezza massima 	I
<ul style="list-style-type: none"> ● Reaktionskräfte in Betrieb ■ Reaktionskräfte außer Betrieb ▲ Ohne Last, Ballast und Transportachse, mit Maximalausleger und Maximalhöhe. 	D	<ul style="list-style-type: none"> ● Reacciones en servicio ■ Reacciones fuera de servicio ▲ Sin carga, sin lastre, ni tren de transporte, flecha y altura máxima. 	E	<ul style="list-style-type: none"> ● 工作状态下的反应 ■ 非工作状态下的反应 ▲ 空载无压重也无运输车有吊臂和最大高度 	C

Mécanismes
Antriebe

Mechanisms
Mecanismos

Meccanismi
机构

						ch - PS hp	kW	
▲	6 L2 V6 1	400 V	m/min kg	— —	18 1200	36 600	6	4,4
	6 PC 6 1	400 V	m/min kg	4,5 1200	18 1200	36 600	6	4,4
	6 PC 7 2	400 V	m/min kg	9,5 1500	19 1500	38 750	6	4,4
▲	6 LVF 6 1	230 V \neq	m/min kg	↑ 3,6 ↓ 3,6 1200 1200	↑ 12,5 ↓ 20 1200 1200	↑ 20 ↓ 36 600 600	5,5	4
		400 V	m/min kg	↑ 3,6 1200	↑ 20 1200	↑ 36 600		
◀ ▶	1 D1 V2	230 V/400 V 400 V	m/min	28			1,5 1	1,1 0,75
⦿	RVF 20		tr/min U/min rpm	0 → 1			1,4	1

CEI 38	IEC 38	kVA	
230 V(+6% -10%) 50 Hz \neq 400 V(+6% -10%) 50 Hz		230 V : 6 kVA 400 V : 9 kVA	84/534 - 87/405

LMM 1

<ul style="list-style-type: none"> ▲ Levage ◀ ▶ Distribution ⦿ Orientation \neq 50 Hz Monophasé Conforme aux directives CEE 84/534 et 87/405 sur le niveau acoustique 	F	<ul style="list-style-type: none"> ▲ Hoisting ◀ ▶ Trolleying ⦿ Slewing \neq 50 Hz Single phase In compliance with the EEC 84/534 and 87/405 Instructions on noise level 	GB	<ul style="list-style-type: none"> ▲ Sollevamento ◀ ▶ Diritribuzione ⦿ Rotazione \neq 50 Hz Monofase Conforme alle direttive CEE 84/534 e 87/405 sul livello acustico 	I
<ul style="list-style-type: none"> ▲ Heben ◀ ▶ Katzfahren ⦿ Schwenken \neq 50 Hz Einphasige Gemäss EWG-Richtlinien 84/534 und 87/405 für den Schall-Leistungspegel 	D	<ul style="list-style-type: none"> ▲ Elevación ◀ ▶ Distribución ⦿ Orientación \neq 50 Hz Monofasica Conforme con las directivas CEE 84/534 y 87/405 sobre el nivel acustico 	E	<ul style="list-style-type: none"> ▲ 起升 ◀ ▶ 变幅 ⦿ 回转 \neq 电源 : 50 Hz 单相 符合 CEE 84/534 - CEE 87/405 声晌度规定 	C

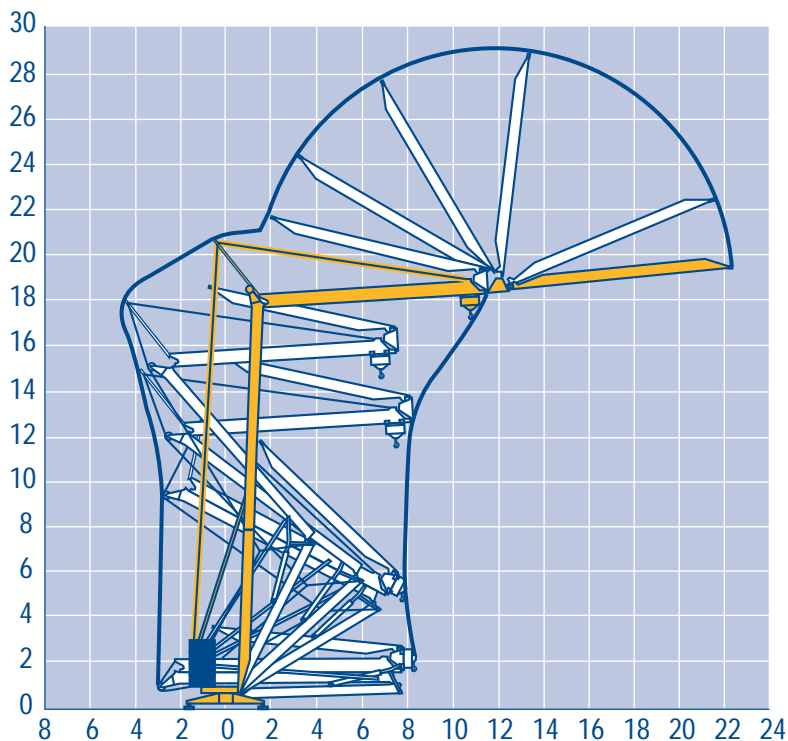

- DS51/S70 ○
- DS60/S80 ○
- DS60/S105
- DS65/S65
- DS95/S105
- DJ126M/S105

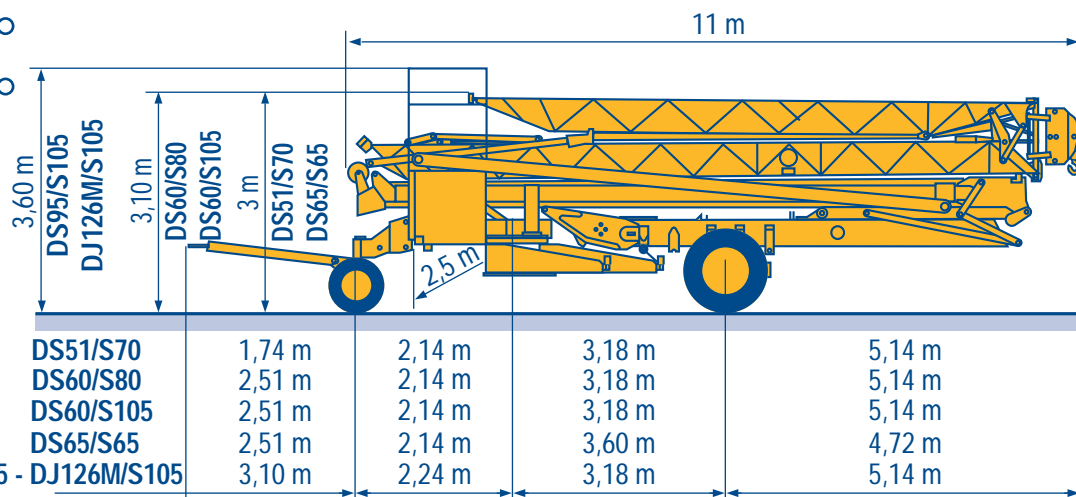

18.Rue de Charbonnières, B.P. 173-F
69132 ECULLY Cedex
Tél. (33)04.72.20.20.20
Fax (33)04.72.20.20.00
<http://www.potain.fr>
E-mail : mkt@potain.fr

HD 14 C

Copyright.Reproduction interdite © POTAIN 1997

Deutschland
POTAIN GmbH Tel : 06.105.704.0
Italia
POTAIN S.p.A. Tel : 039.65.631
China
Zhangjiagang POTAIN Tel : 520. 877.1451