

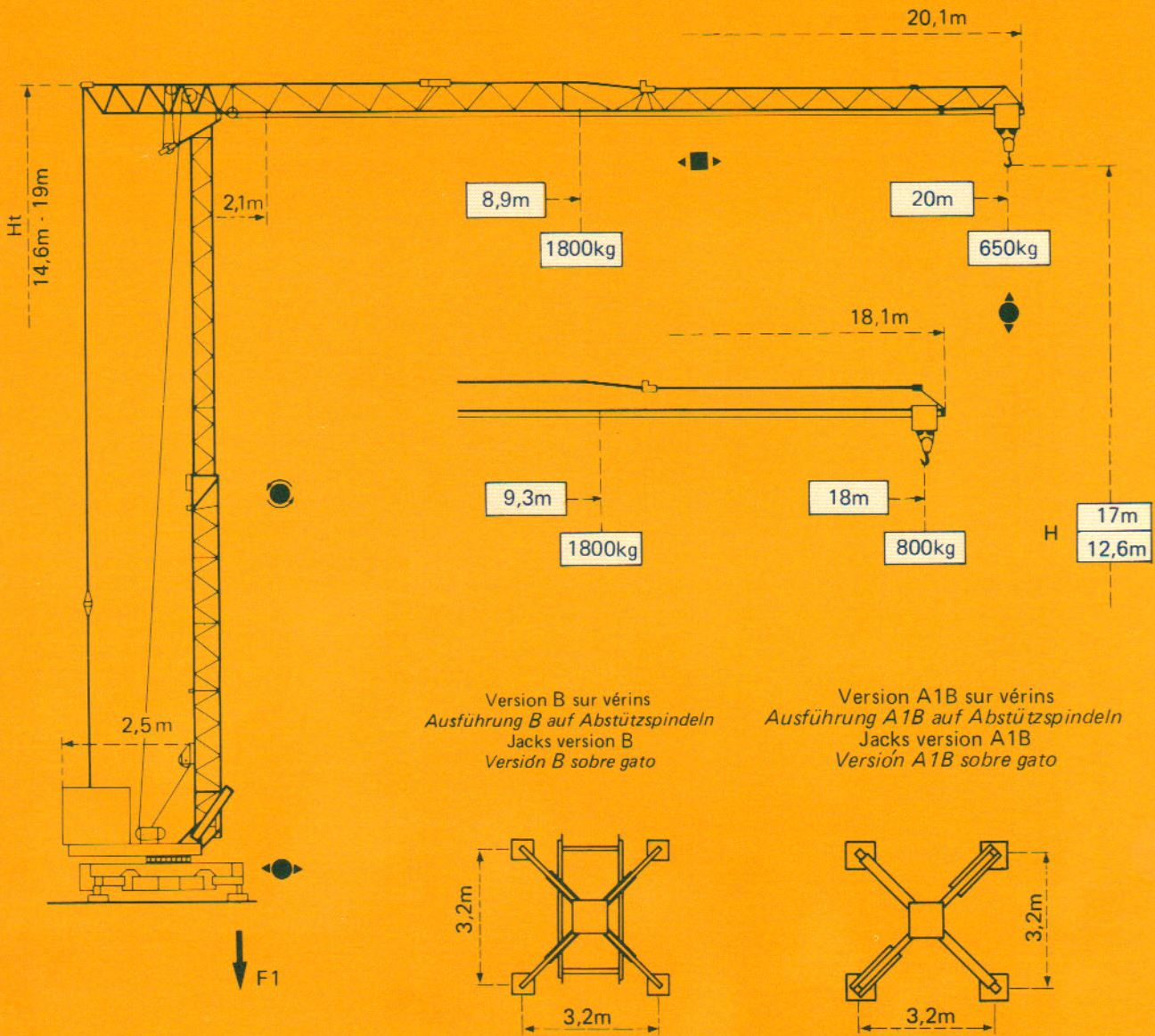

GMR 313B/A1B

POTAIN 



F1 = Réactions Eckdrücke Reactions Reacciones

F1	● 8 t	■ 4,3 t
	5,5 t	

- En service
- Hors service

 A vide sans lest ni train de transport, avec flèche et hauteur maximum.

- In Betrieb
- Ausser Betrieb

 Ohne Last, Ballast und Transportachse, mit Maximalausleger und Maximalhöhe.

- In service
- Out of service

 Without load, ballast or transport axles, with maximum jib and maximum height.

- En servicio
- Fuera de servicio

 Sin carga, sin lastre, ni tren de transporte, flecha y altura maximas.

Courbes de charges Lastkurven Load diagrams Curvas de cargas

 Flèche Ausleger Jib Flecha

2,1 →	8,9	10	10,3	11	12	13	14	15	16	17	18	19	20	m
20m 	1800	1550	1500	1370	1230	1120	1020	940	860	800	740	690	650	kg

2,1 →	9,3	10	10,8	11	12	13	14	15	16	17	18	m
18m 	1800	1650	1500	1470	1320	1200	1090	1000	930	860	800	kg

Flèche relevée Ausleger in Steilstellung Luffing jib Flecha izada



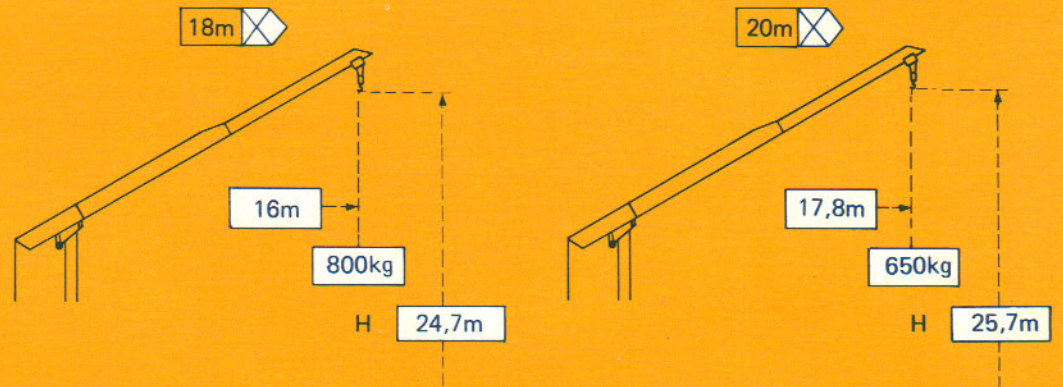



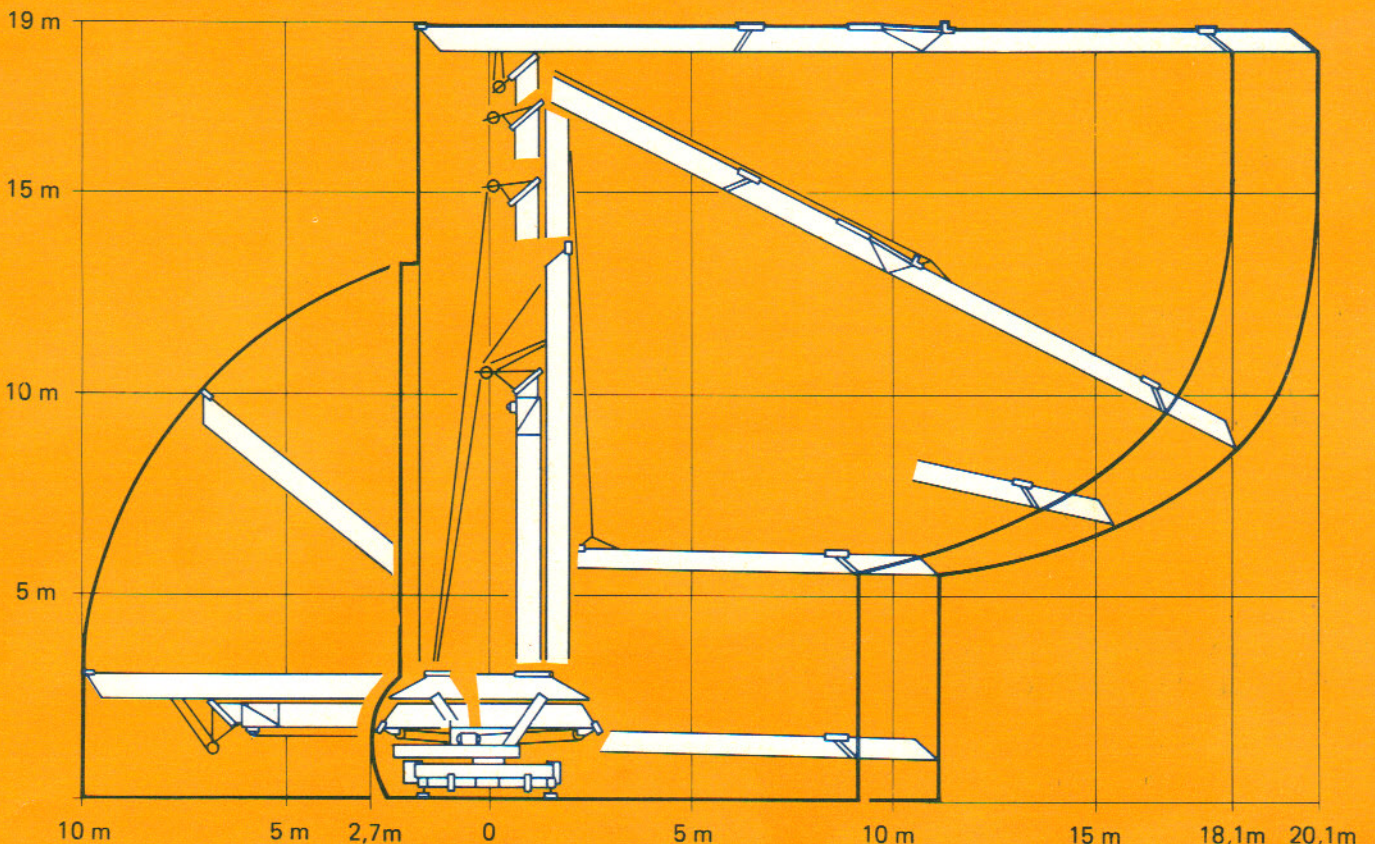



Chariot bloqué
(version standard)
Verriegelte Laufkatze
(Standardausführung)
Trolley locked
(standard crane)
Carro bloqueado
(version standard)



Montage Montage Erection Montaje



Mécanismes Antriebe Mechanisms Mecanismos

			m/min.	kg	ch-PS hp	kW
Levage Heben Hoisting Elevación	S1  9TDPC9		20	1800	6,8	5
			40	900		
			5	1800	1,6	1,2
			20	1800	6,8	5
			40	900		
Distribution - <i>Katzfahren</i> Trolleying - <i>Distribución</i>		1DV1	35		1,4	1
Orientation - <i>Schwenken</i> Slewing - <i>Orientación</i>		MCS10	0,3 - 1 tr/min U/min-rpm		1	0,8
Réseau - <i>Netzstrom</i> - Mains supply - <i>Red</i>					380V - 50 HZ	
Puissance électrique nécessaire - <i>Anschlusswert</i> - Necessary electric power - <i>Potencia electrica necesaria</i>					16 KVA	
Groupe électrogène - <i>Stromaggregat</i> - Generator set - <i>Grupo electrogeno</i>					.	

*Nous consulter - *Auf Anfrage* - Consult us - *Consultarnos*

Transport Transport Transport Transporte

Version B : grue avec 2 essieux débrochables tractée derrière camion
Ausführung B : Kran mit 2 abnehmbaren Standardtransportachsen als LKW-Anhänger
 Version B : Crane with 2 removable axles towed behind lorry
 Version B : Grua con 2 ejes de transporte desmontables remolcada con camión

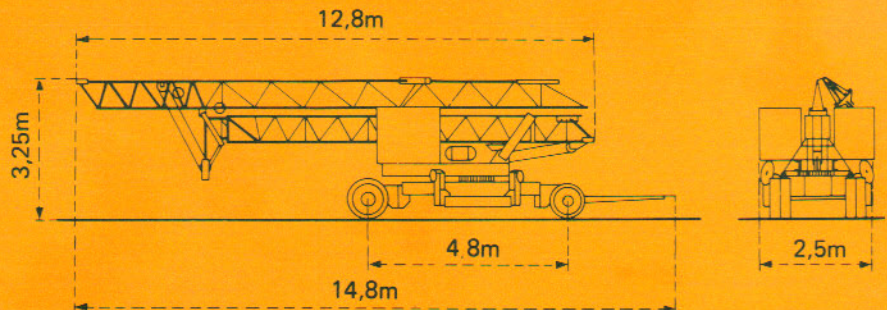

Version A1B : grue avec 1 essieu fixe tractée derrière camion
Ausführung A1B : Kran mit 1 fest angebaute Transportachse als LKW-Anhänger
 Version A1B : Crane with 1 fixed axle towed behind lorry
 Version A1B : Grua con 1 eje fijo remolcada con camión

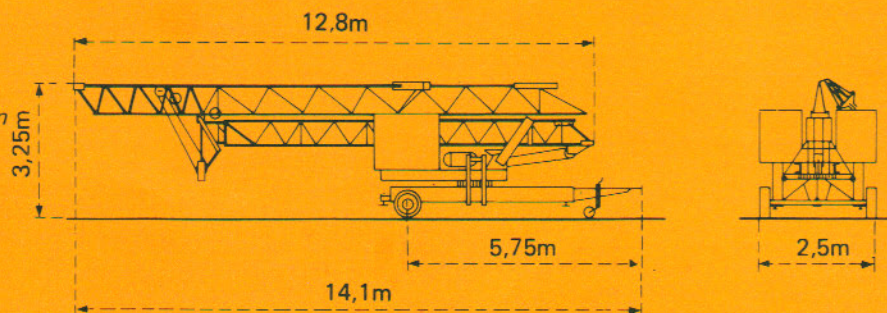

NF E 52081 - 82

DIN 15018 H1 B3

POTAIN 

18, rue de Charbonnières B.P. 173 - F 69132 ECULLY Cedex
 Tél. 78.33.81.81 — Télex 330 179 Télex Export 375 213

POTAIN GmbH 6082 MÖRFELDEN WALLDORF
 Nordendstr. 79-87 - Postfach 420
 Tél. 06 105 704.0 - Télex 4.1857 45

GMR 313B/A1B

Ref. 8452 KMT 3

Modifications réservées - Änderungen vorbehalten - Subject to modification - Modificaciones reservadas

Printed in France