

20 m  
11,5 m

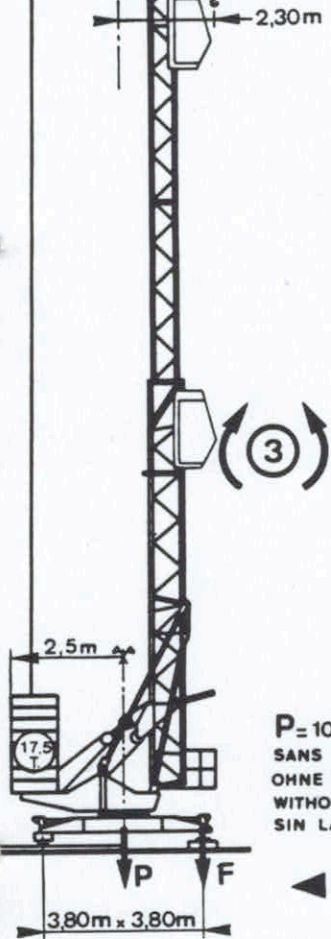

**P = 10800 kg**  
 SANS LEST SANS TRAIN  
 OHNE BALLAST OHNE TRANSPORTACHSE  
 WITHOUT BALLAST WITHOUT TOWING AXLE  
 SIN LASTRE SIN TREN

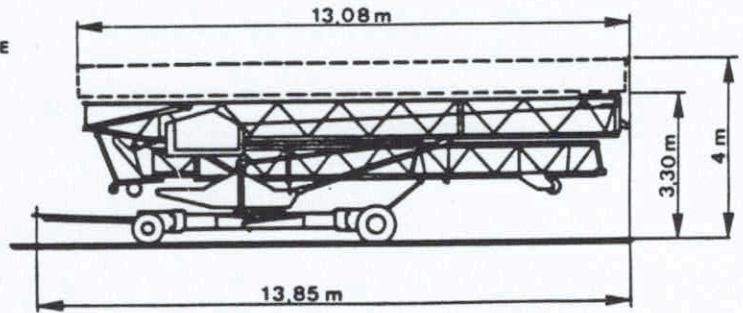

**F = 17000 daN**  
 EN SERVICE  
 IN BETRIEB  
 IN SERVICE  
 EN SERVICIO

**F = 10 000 daN**  
 HORS SERVICE  
 AUSSER BETRIEB  
 OUT OF SERVICE  
 FUERA DE SERVICIO

50Hz	60Hz	kg	m/mn	kW
15 TDP C 10			4 / 4.8	3.7
			8 / 9.6	4.4
			12.5 / 15	11
			25 / 30	13.2
			25 / 30	11
			50 / 60	13.2

	380V-50Hz = 20KVA	450V-60Hz = 24KVA
3D2V5	22-44 m/mn	3.3 kW
	26-52 m/mn	4 kW
3D1V5	35 m/mn	3.3 kW
	42 m/mn	4 kW
RCV 20	0 → 1 tr/mn	2.2 kW
	0 → 1.2 tr/mn	2.6 kW
TVD 121	25 m/mn	2 x 1 kW
	30 m/mn	2 x 1.2 kW



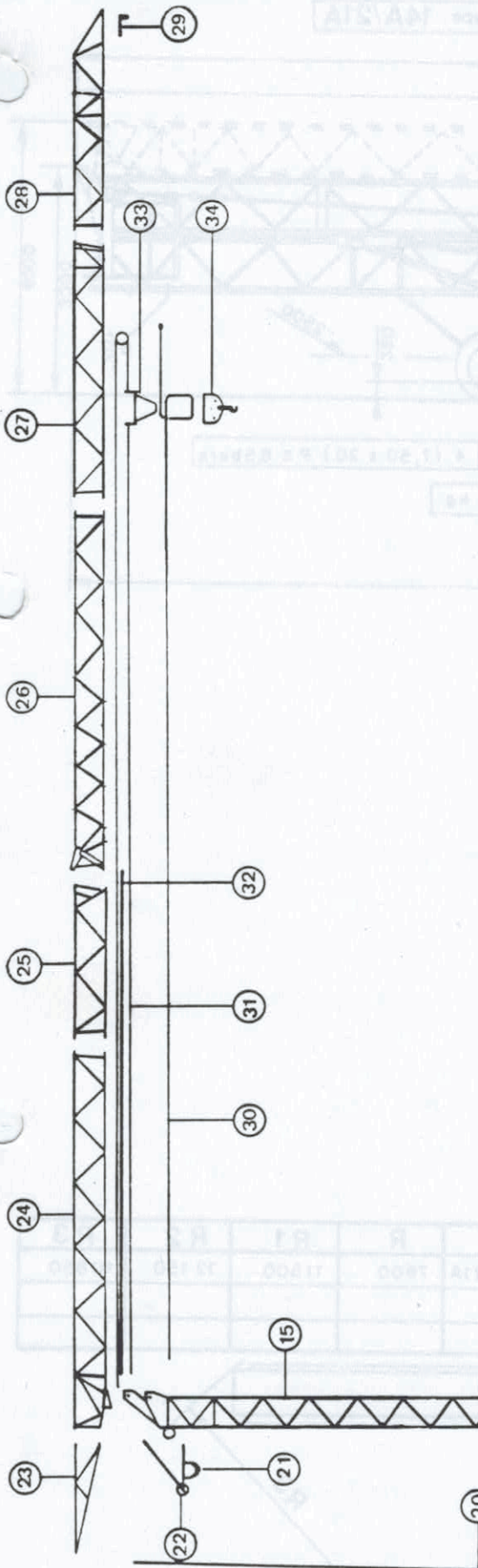

Rep	kg ±5%	mm ±5%	Rep	kg ±5%	mm ±5%	Rep	kg ±5%	mm ±5%
1	4 x 14		15		11730	29	26	415 x 465 x 300
2	2 x 65 2 x 110		16	50		30	48	
3	1865	4230 x 2110 x 530	17	330		31	10 5	16 7
4	270	∅ 1144 x 100	18	4		32	264	
5	1130	3295 x 1355 x 1165	19	63		33	102	920 x 740 x 780
6	415	1644 x 475 x 712	20	180		34	142	590 x 355 x 150
7	160		21	107	770 x 340 x 390	35	36	
8	75	820 x 420 x 335	22	74	1200 x 720 x 400	36	272	2170 x 830 x 1110
9	15		23	180	2200 x 700 x 575			
10	130	840 x 240	24		9230 970 700			
11	105	680 x 850 x 340	25		3670 850 610			
12	114 120	4215 x 132 x 460	26	360	8175 x 610 x 930			
13	180	4490 x 132 x 130	27	160	4915 x 670 x 860			
14		9820 1360 1120	28	90	3085 x 735 x 770			

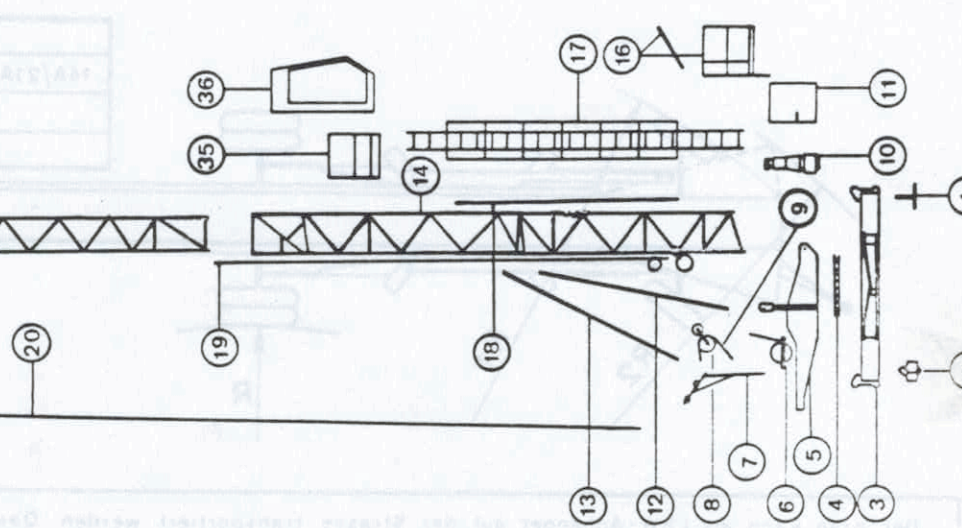



Transport non lesté / Transport ohne Ballast / Transport without Ballast

Equipement de transport / Transportachsen / Wheel units - type: 14A/21A

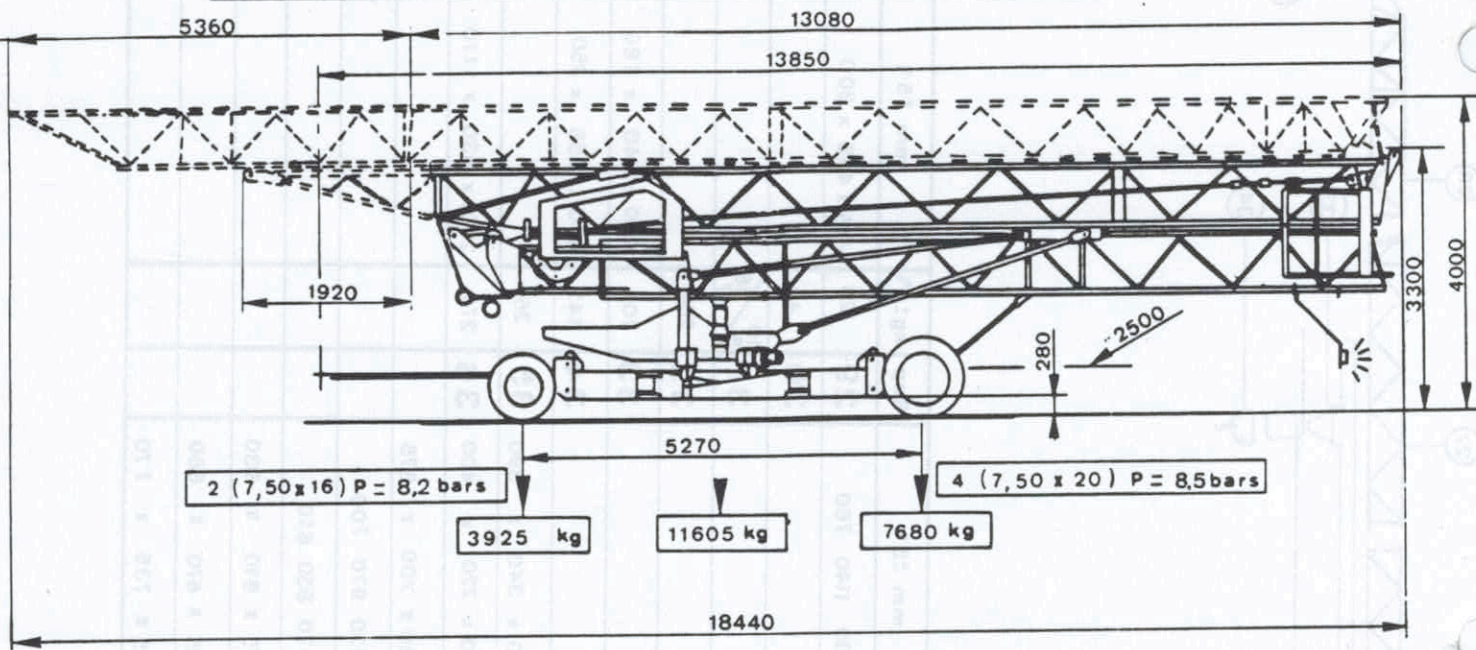

14	180	150	102	138	18	32	146	110	130	1	3	5	1
13	180	150	114	138	18	32	146	110	130	1	3	5	1
15	180	150	114	138	18	32	146	110	130	1	3	5	1
11	180	150	102	138	18	32	146	110	130	1	3	5	1
10	180	150	102	138	18	32	146	110	130	1	3	5	1
6	180	150	102	138	18	32	146	110	130	1	3	5	1
8	180	150	102	138	18	32	146	110	130	1	3	5	1
3	180	150	102	138	18	32	146	110	130	1	3	5	1
6	180	150	102	138	18	32	146	110	130	1	3	5	1
8	180	150	102	138	18	32	146	110	130	1	3	5	1
9	180	150	102	138	18	32	146	110	130	1	3	5	1
3	180	150	102	138	18	32	146	110	130	1	3	5	1
5	180	150	102	138	18	32	146	110	130	1	3	5	1
1	180	150	102	138	18	32	146	110	130	1	3	5	1
6	180	150	102	138	18	32	146	110	130	1	3	5	1

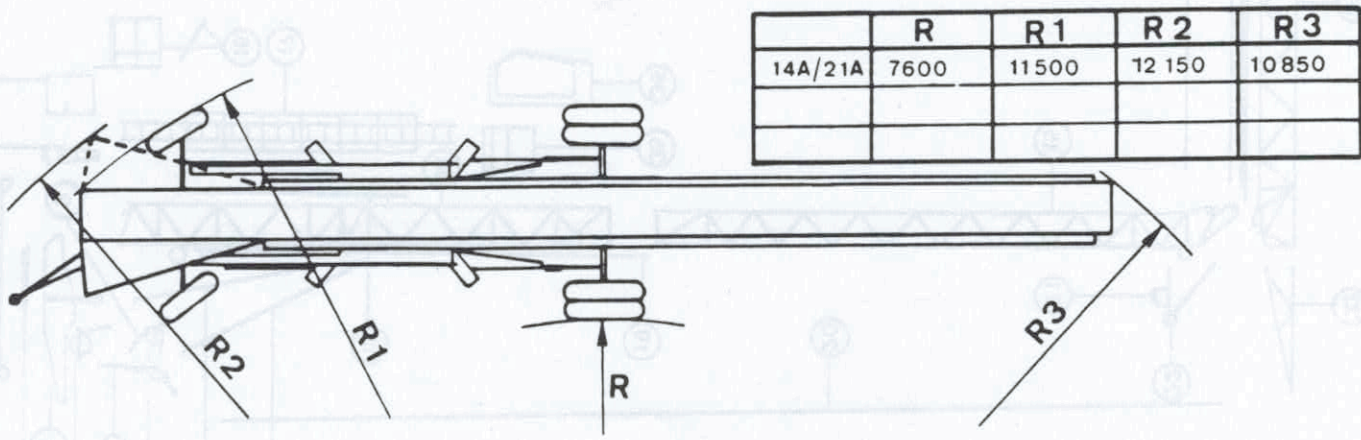

	R	R1	R2	R3
14A/21A	7600	11500	12 150	10850

Der Kran kann als LKW-Anhänger auf der Strasse transportiert werden. Das Strassenfahrwerk entspricht den gültigen Vorschriften (StVZO).  
 Für den Transport auf öffentlichen Strassen sind die besonderen Vorschriften und Auflagen der Betriebserlaubnis und Ausnahmegenehmigung zu beachten.

Transport lesté / Transport mit Ballast / Transport with Ballast

Equipement de transport / Transportachsen / Wheel units : Type 15A/25A - 18/27

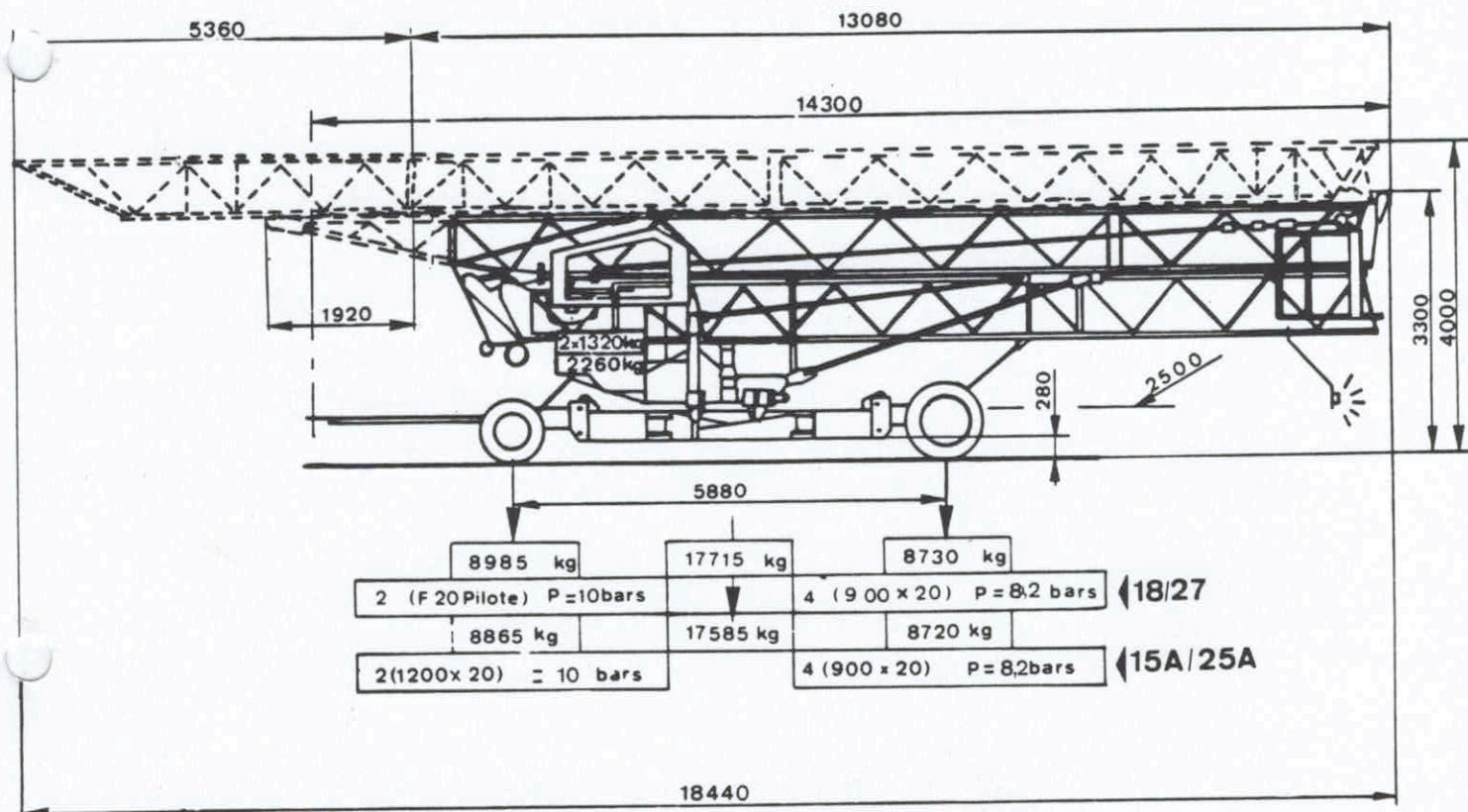
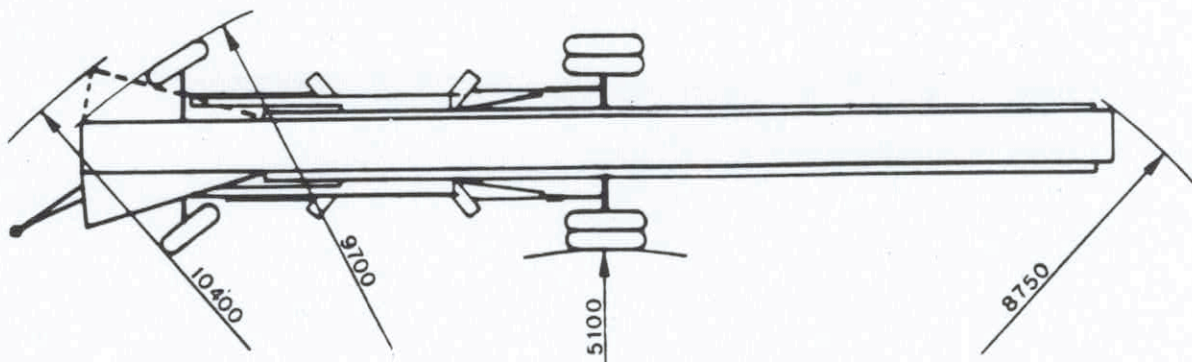

Der Kran kann als LKW-Anhänger auf der Strasse transportiert werden. Das Strassenfahrwerk entspricht den gültigen Vorschriften (StVZO)

Für den Transport auf öffentlichen Strassen sind die besonderen Vorschriften und Auflagen der Betriebserlaubnis und Ausnahmegegenehmigung zu beachten.



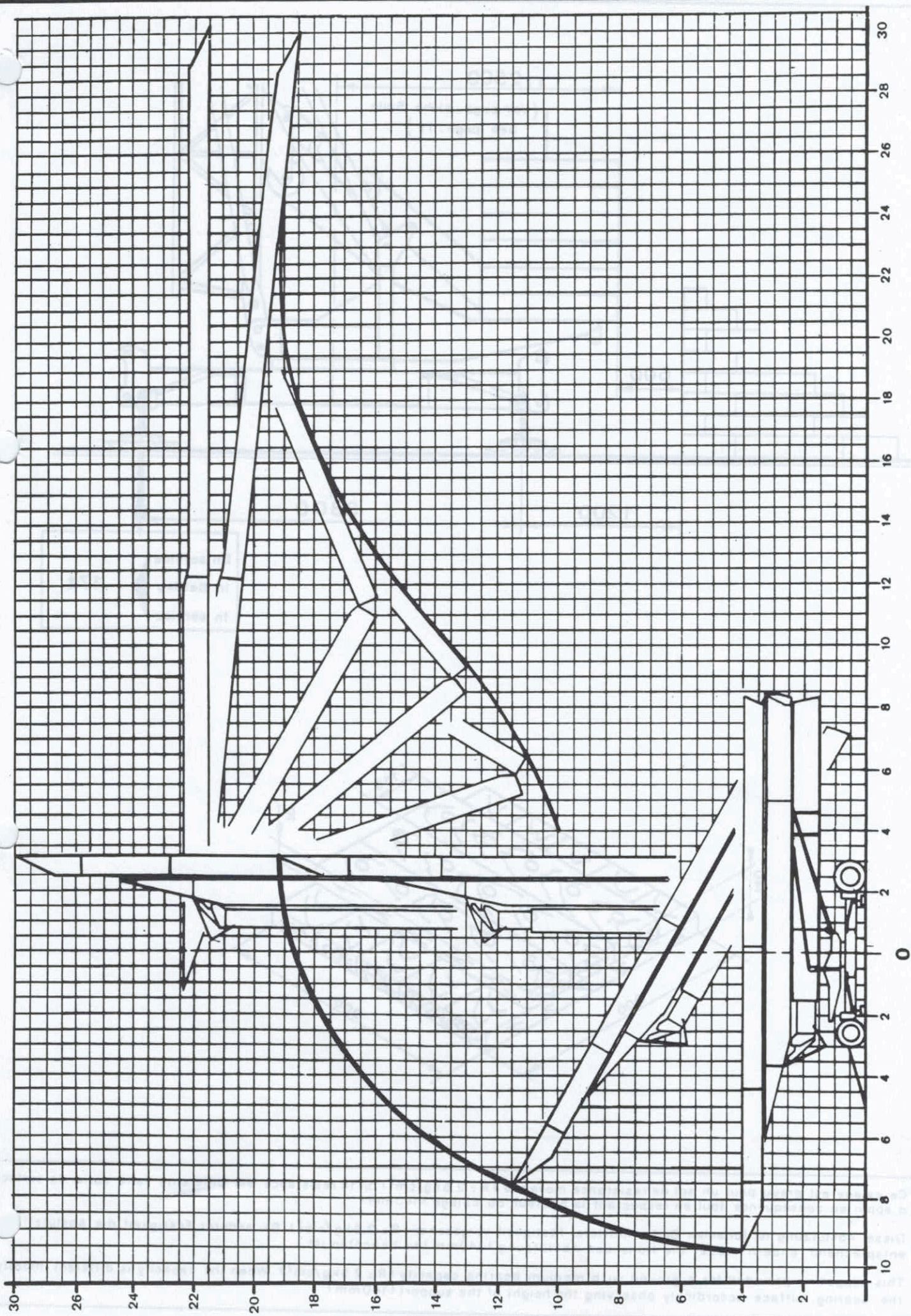

1 Carreau  
1 Quadrat  
▲ : 50 cm



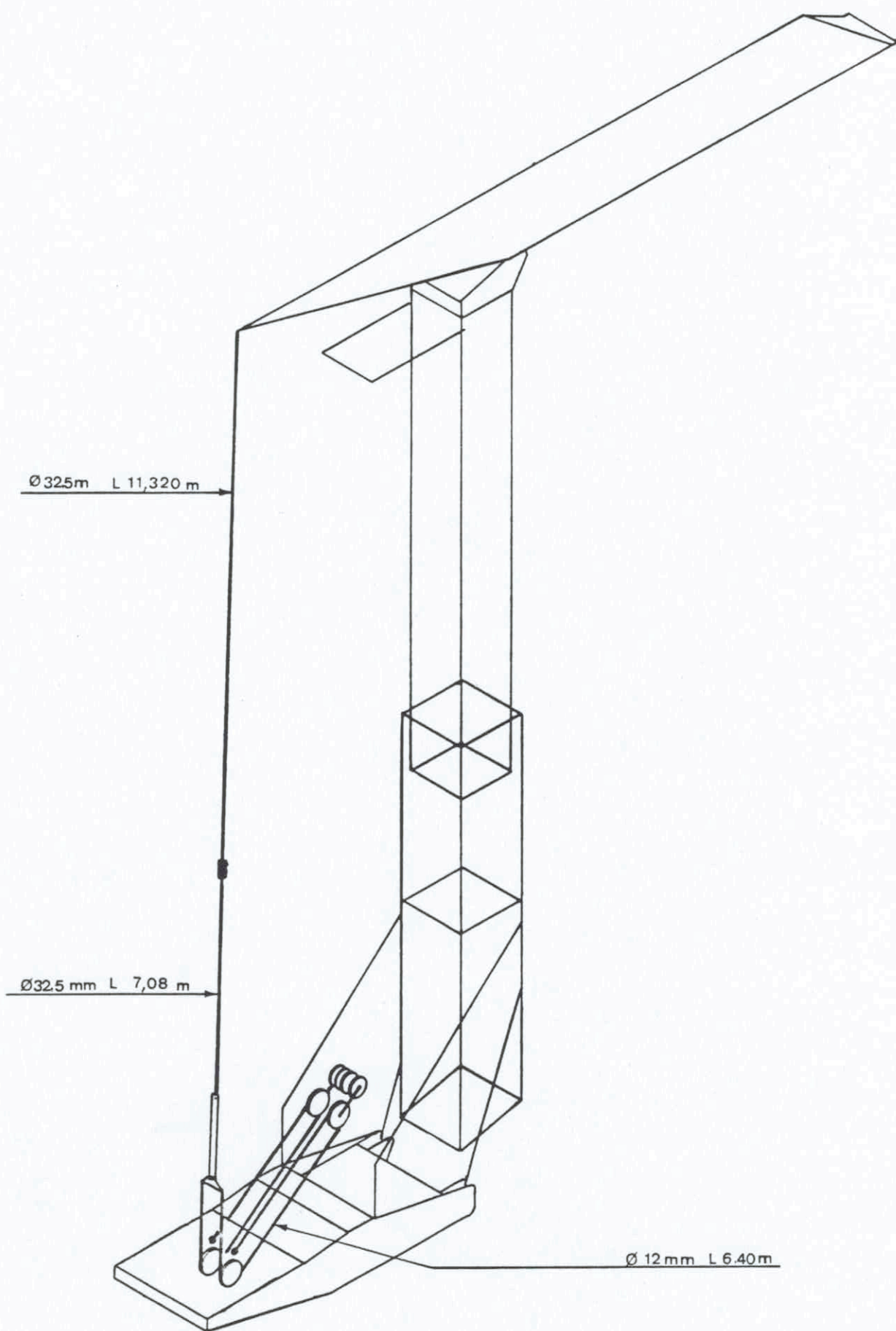

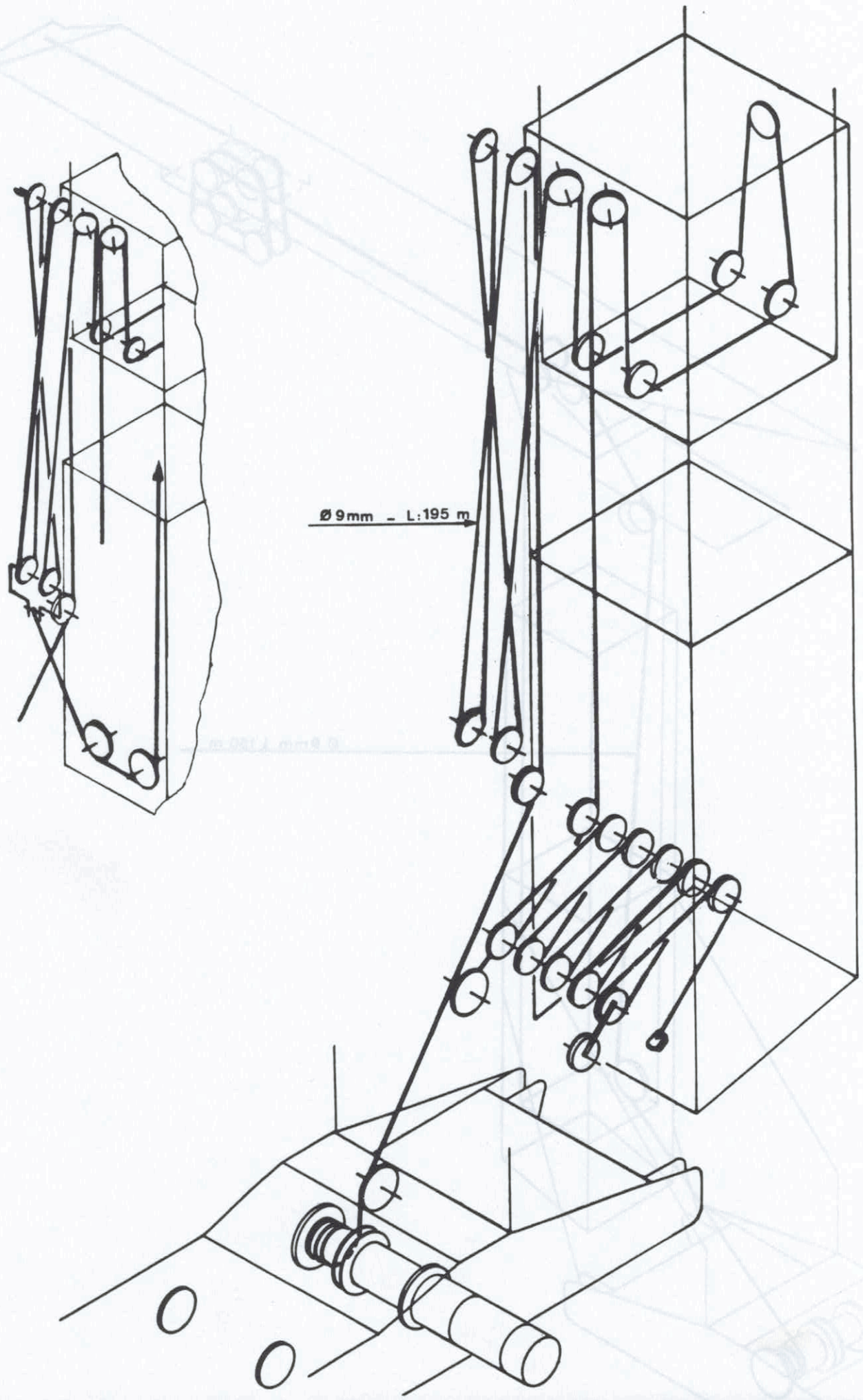

$\varnothing 9\text{mm} - L:195\text{m}$

