

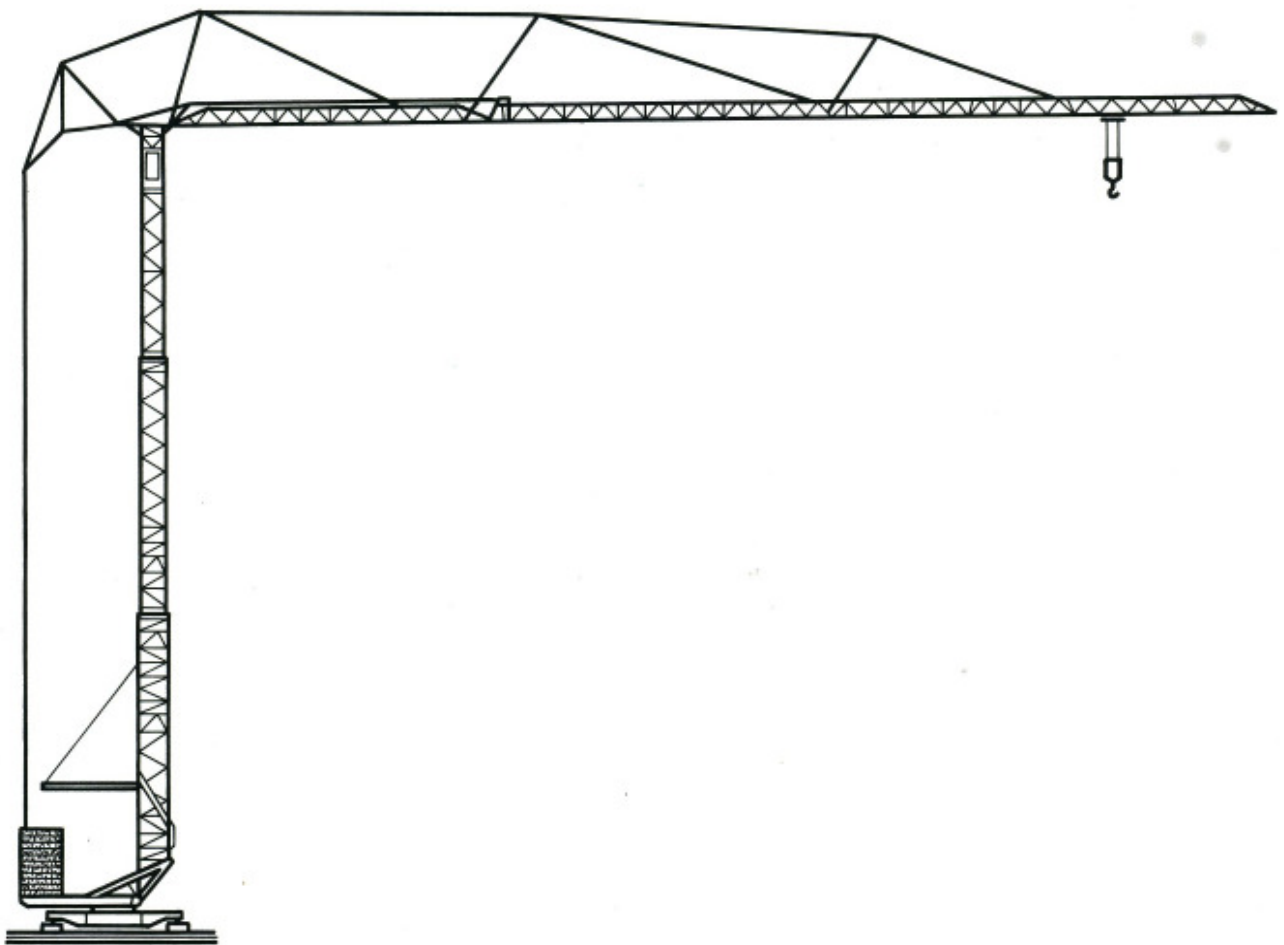

# BPR-Cadillon



## CHRONO 55

NF E 52081 - E 52082

DIN 15018 H1 B3 K3



# CHRONO 55

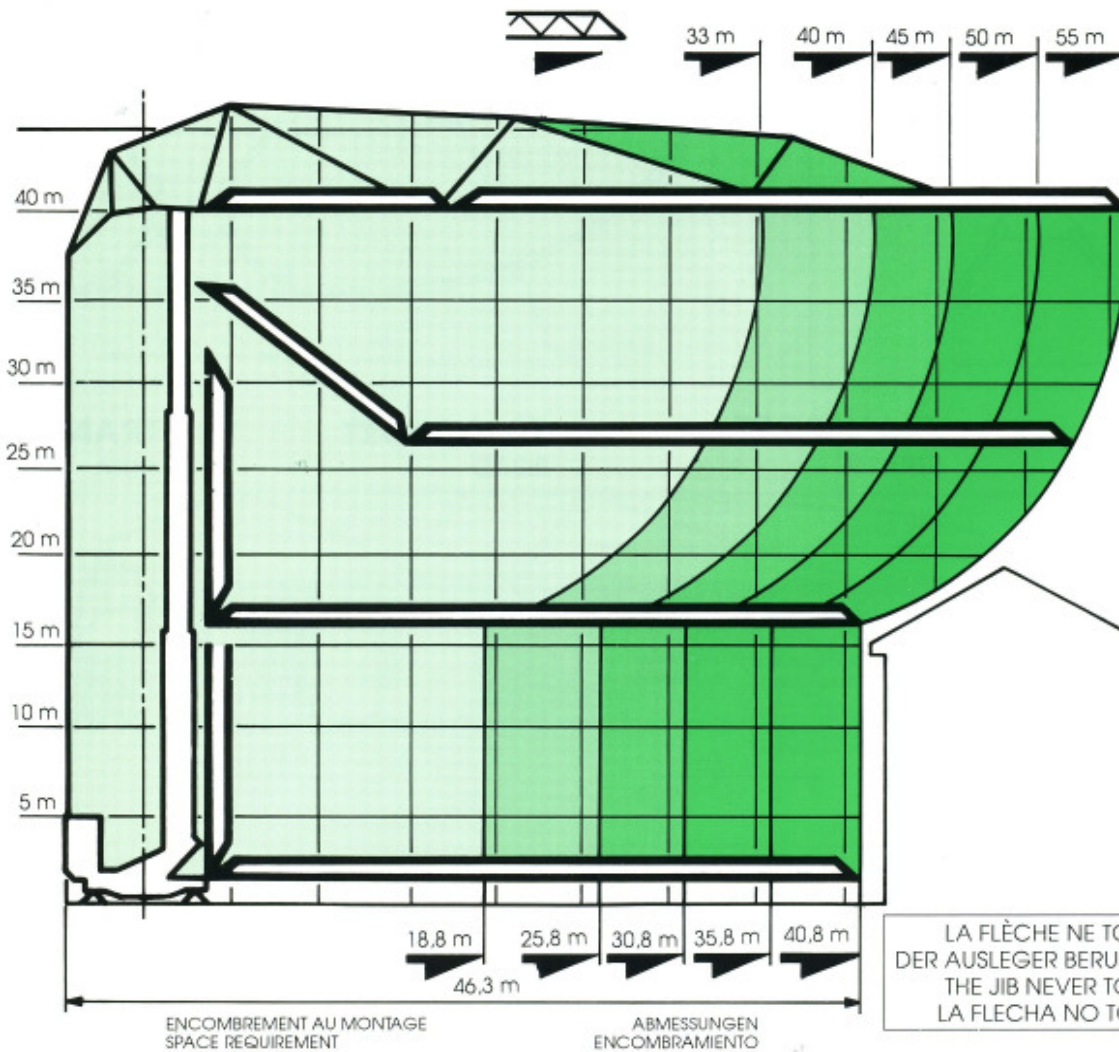

CHRONO 55		m/mn	KW	$c^h$ PS - HP	kg
	I	2,7	4,4	6	10000
	II	15	24	33	10000
	III	30	24	33	5000
	I	5,4	4,4	6	5000
	II	30	24	33	5000
	III	60	24	33	2500
		0,1 > 0,3 > 0,7	2 X 4,5	2 X 6	
		15 > 30 > 60	4,5	6	
		10 > > 25	4 X 2,2	4 X 3	

V	380	450
Hz	50	60
kVA	50	60
GROUPE ELECTROGENE STROMAGGREGAT GENERATOR SET GRUPO ELECTROGENO		
V	380	450
Hz	50	60
kVA	120	150



# CHRONO 55

## VERSIONS SUR CHASSIS

## UNTERWAGEN

## UNDERCARRIAGE

## CHASIS

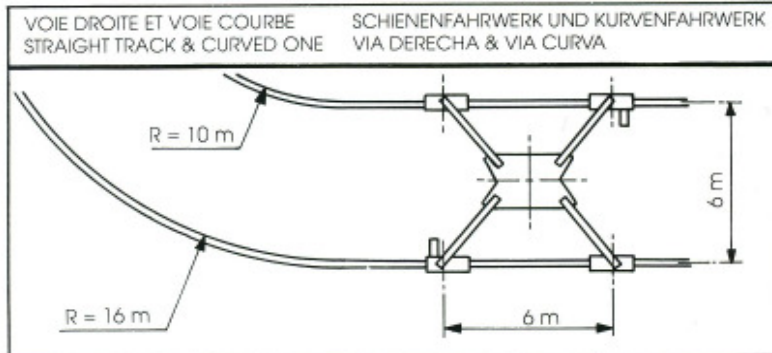
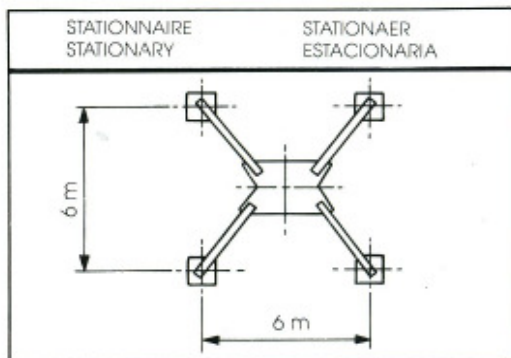

## TRANSPORT ROUTIER

## TRANSPORT STRASSE

## TRANSPORT ROAD

## TRANSPORTE RUTA

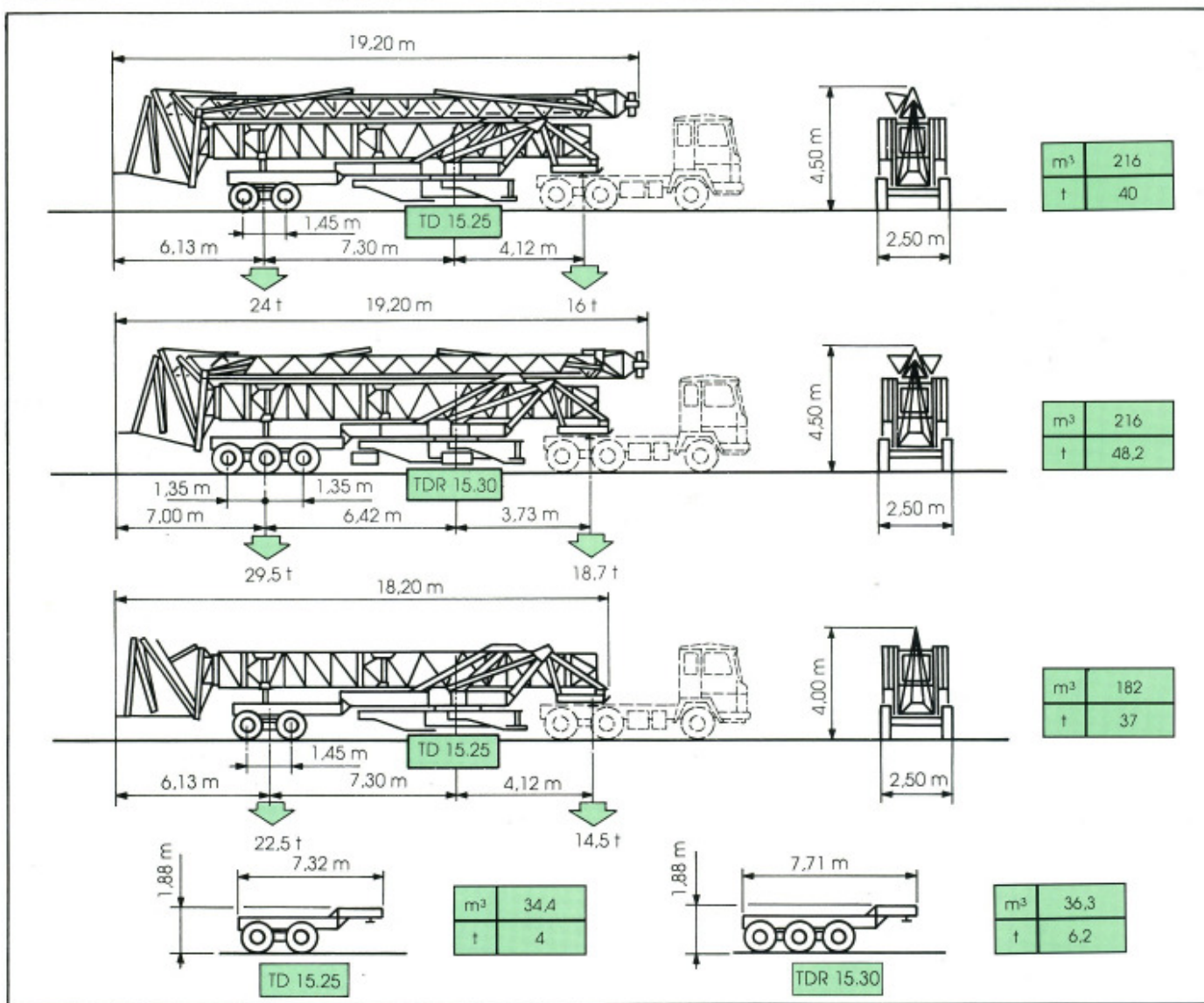

Siège social : 17, rue de Verdun - BP 25 - 71120 CHAROLLES - France  
 Tél. : 85 24 09 34 - Fax : 85 88 34 10  
 138, rue Julian Grimau - 94408 VITRY-SUR-SEINE Cedex - France  
 Tél. : (1) 45 73 39 70 - Télex : 260 728 - Fax (1) 46 73 39 79  
 11, rue la Ligne de l'Est - 69627 VILLEURBANNE Cedex  
 Tél. : (33) 72 34 99 00 - Fax : (33) 72 34 99 20  
 CADILLON BAUMASCHINEN G.m.b.H. : Am Dornbusch 4 - D 6108 WEITERSTADT  
 DEUTSCHLAND - Tél. 0 6151/98050 - Fax 980515

DATA N° 267.7.0493

Modifications réservées - Änderungen vorbehalten - Subject to modification - Modificaciones reservadas

TURBOMAT - 71225 BEAUBERY - 015 24 14 15