

Snelmontagekraan
 Grue à montage rapide
 Schnelleinsatzkran
 Self erecting crane

T 33CR

STATIONAIR

KRAAN OP RUPS
 GRUE SUR CHENILLES
 CRAWLER-CRANE
 RAUPENKRAN

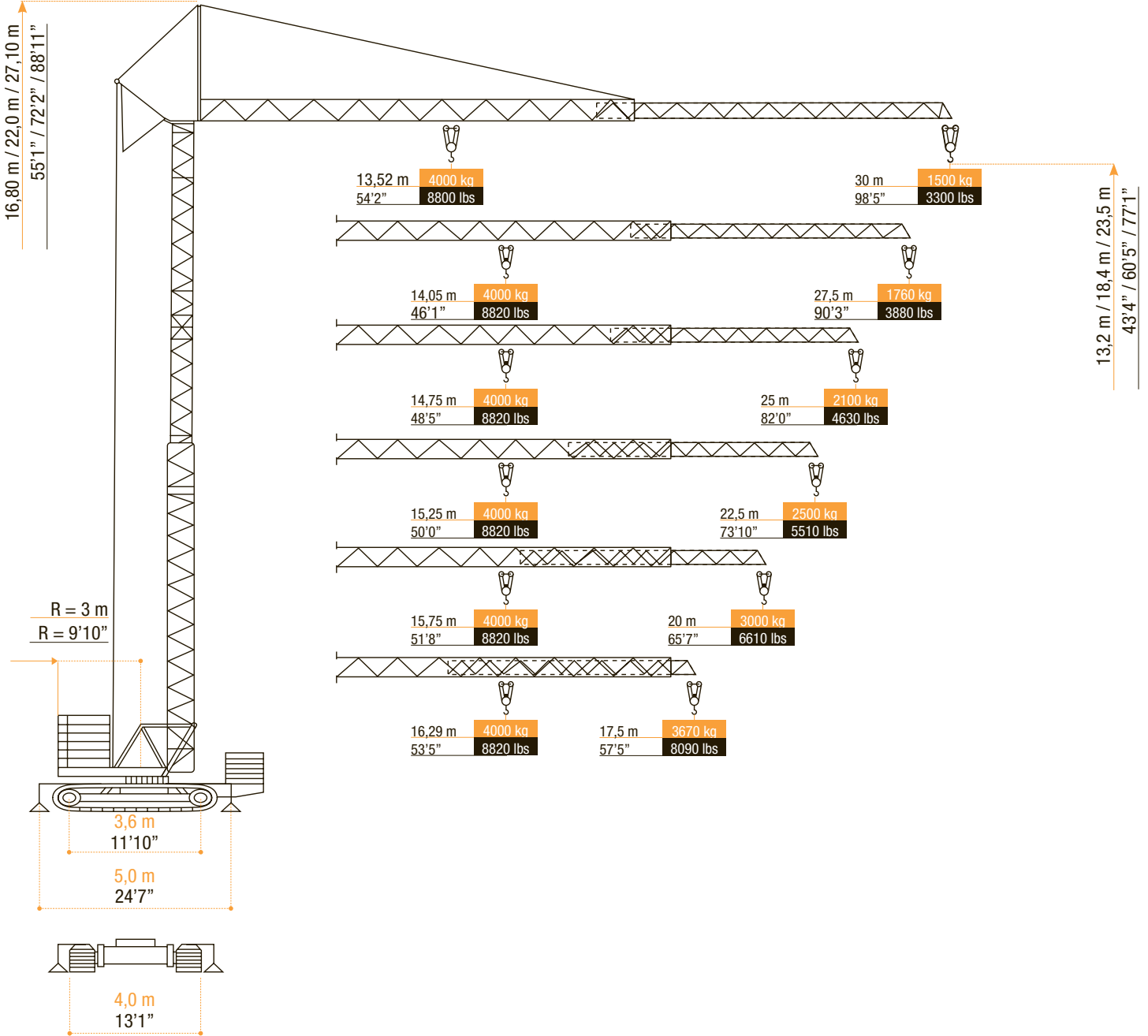

ARCOMET

www.arcomet.com



LASTENTABEL - COURBES DE CHARGES - LOAD CURVES - LASTKURVEN - CURVE DI CARICO - CURVAS DE CARGAS

m	13,52	14	15	16	17	18	19	20	21	22	23	24	25	26	27	28	29	30
kg	4000	3833	3521	3252	3020	2816	2636	2476	2332	2203	2086	1980	1882	1793	1711	1635	1565	1500
ft	44'4"	45'11"	49'3"	52'6"	55'9"	59'1"	62'4"	65'7"	68'11"	72'2"	75'6"	78'9"	82'0"	85'4"	88'7"	91'10"	95'2"	98'5"
lbs	8820	8450	7760	7170	6660	6210	5810	5460	5140	4860	4600	4370	4150	3950	3770	3610	3450	3310

m	14,05	15	16	17	18	19	20	21	22	23	24	25	26	27,5
kg	4000	3691	3411	3168	2955	2767	2599	2449	2314	2192	2081	1979	1886	1760
ft	46'1"	49'3"	52'6"	55'9"	59'1"	62'4"	65'7"	68'11"	72'2"	75'6"	78'9"	82'0"	85'4"	90'3"
lbs	8820	8140	7520	6980	6520	6100	5730	5400	5100	4830	4590	4360	4160	3880

m	14,75	15	16	17	18	19	20	21	22	23	24	25
kg	4000	3904	3608	3352	3128	2930	2753	2595	2453	2324	2207	2100
ft	48'5"	49'3"	52'6"	55'9"	59'1"	62'4"	65'7"	68'11"	72'2"	75'6"	78'9"	82'0"
lbs	8820	8610	7950	7390	6900	6460	6070	5720	5410	5120	4870	4630

m	15,25	16	17	18	19	20	21	22,5
kg	4000	3773	3506	3272	3066	2882	2717	2500
ft	50'0"	52'6"	55'9"	59'1"	62'4"	65'7"	68'11"	73'10"
lbs	8820	8320	7730	7210	6760	6350	5990	5510

m	15,75	16	17	18	19	20
kg	4000	3925	3648	3405	3191	3000
ft	51'8"	52'6"	55'9"	59'1"	62'4"	65'7"
lbs	8820	8650	8040	7510	7040	6610

m	16,29	17,5
kg	4000	3670
ft	53'5"	57'5"
lbs	8820	8090



m	24,81	25	26	27	28	29	30
kg	2000	1982	1893	1811	1735	1665	1600
ft	81'5"	82'0"	85'4"	88'7"	91'10"	95'2"	98'5"
lbs	4410	4370	4170	3990	3830	3670	3530

HOEKDRUKKEN - RÉACTIONS - REACTIONS - ECKDRÜCKE - REAZIONI - REACCIONES

kg	57 360	>gewicht kraan + rupsonderstel + ballast>Poids de la grue + chassis chenillard + lest
lbs	126 460	>Weight of crane + Crawler chassis + Ballast>Gewicht von Kran + Raupenunterwagen + Ballast

	kN	200		kN	250
	kips	45		kips	56

kg	29 600	>gewicht kraan + rupsonderstel	>Poids de la grue + chassis chenillard
lbs	65 260	>Weight of crane + Crawler chassis	>Gewicht von Kran + Raupenunterwagen

bodemdruk 0,8 kg/cm

kg	16 600	>gewicht kraan + rupsonderstel (zonder rupschepen)	>Poids de la grue + chassis chenillard (sans les chenilles)
lbs	36 600	>Weight of crane + Crawler chassis (Without crawler tracks)	>Gewicht von Kran + Raupenunterwagen (Ohne Raupen)

	kg	29 600
	lbs	65 260

AANDRIJVINGEN - MÉCHANISMES - MECHANISMS - ANTRIEBE - MECCANISMI - MECANISMOS



	m/min	5,0	22,5	45,0
	kg	2000	2000	1000
	fpm	16	74	148
	lbs	4410	4410	2210
	kW	2,4	11,0	11,0
	HP	~3,2	~14,7	~14,7



	m/min	2,5	11,3	22,5
	kg	4000	4000	2000
	fpm	8	37	74
	lbs	8820	8820	4410
	kW	2,4	11,0	11,0
	HP	~3,2	~14,7	~14,7

	m/min	15 / 30
	fpm	~ 49 / 98

	m/min	15 / 30
	fpm	~ 49 / 98

	m/min	0 - 1 min
	fpm	

	m/min	0 - 1 min
	fpm	

	m/min	20
	fpm	66

	m/min	20
	fpm	66

	kVA	22
--	-----	----

	V	380 V aggregaat aanwezig
--	---	--------------------------

RML

RML

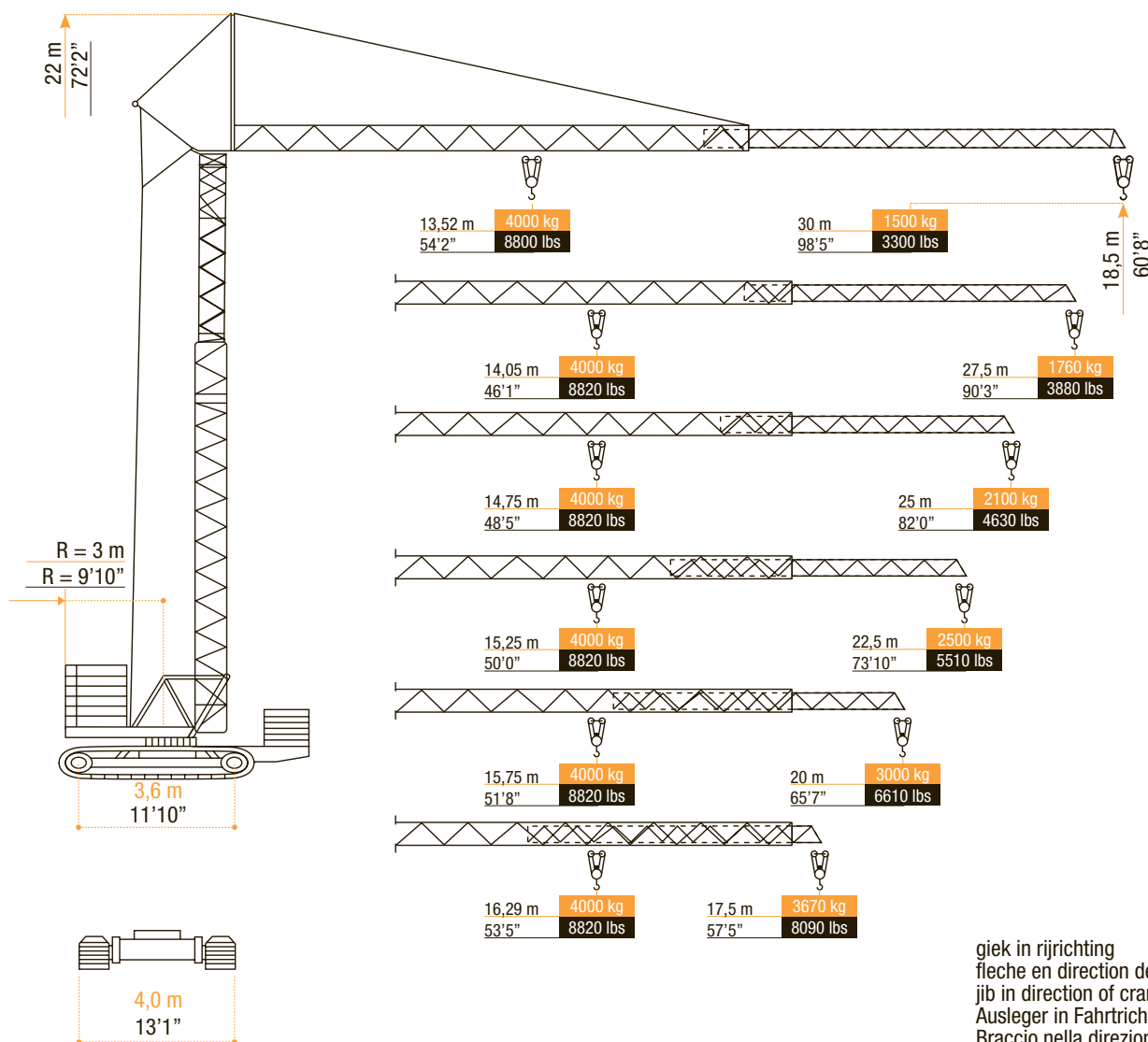





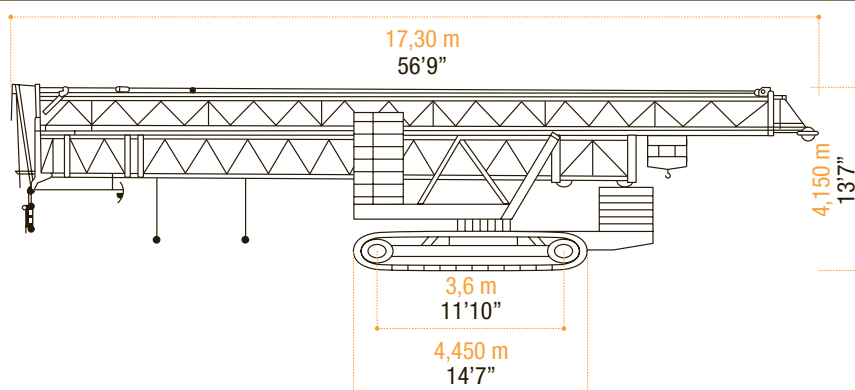











giek in rijrichting
 fleche en direction de conduite
 jib in direction of crane travel
 Ausleger in Fahrtrichtung
 Braccio nella direzione di traslazione

TRANSPORT



MONTAGE PRINCIPE IDENTIEK AAN A 45B - SYSTÈME DE MONTAGE IDENTIQUE À LA A 45B

CRANE ERECTION SYSTEM IDENTICAL AS A 45B - KRANMONTAGESYSTEM GLEICH WIE A 45B - SISTEMA DI MONTAGGIO UGUALE COME A 45B

 <ul style="list-style-type: none"> • in bedrijf • en service • in service • in Betrieb • in servizio • en servicio 	 <ul style="list-style-type: none"> • buiten bedrijf • hors service • out of service • außer Betrieb • fuori servizio • fuera de servicio 	 <ul style="list-style-type: none"> • hijsen • levage • hoisting • heben • sollevamento • elevación 	 <ul style="list-style-type: none"> • loopkatrjden • chariotage • jib trolleying • Katzfahren • traslazione carrello • poleas móviles 	 <ul style="list-style-type: none"> • zwenken • orientation • slewing • Schwenken • rotazione • orientación 	 <ul style="list-style-type: none"> • spanning • tension • voltage • spannung • tensione • tensión 	 <ul style="list-style-type: none"> • gewicht zonder ballast • poids propre sans lest • weight without ballast • gewicht ohne Ballast • peso senza zavorra • peso sin lastre
 <ul style="list-style-type: none"> • lengte • longueur • length • länge • lunghezza • longitud 	 <ul style="list-style-type: none"> • spoor • translation • rail • Kranfahren • carreggiata • rail 	 <ul style="list-style-type: none"> • vermogen • puissance • power • leistung • potenza • potencia 	 <ul style="list-style-type: none"> • micro snelheid • vitesse • speed • Geschwindigkeit • velocità • velocidad 	 <ul style="list-style-type: none"> • 2^o snelheid • 2^o vitesse • 2^o speed • 2^o Geschwindigkeit • 2^o velocità • 2^o velocidad 	 <ul style="list-style-type: none"> • 3^o snelheid • 3^o vitesse • 3^o speed • 3^o Geschwindigkeit • 3^o velocità • 3^o velocidad 	 <ul style="list-style-type: none"> • maximale hoekdruk • réactions • reactions • Eckdrücke : 10 kN = 1t • press. angolare massima • presión angular máxima
 <ul style="list-style-type: none"> • enkel inschering zonder hijsblok • simple mouflage sans moufle • 2 fall reeving without houstingblock • 2 Fach Einsicherung ohne Hakenflasche • passaggio semplice senza paranca • solamente elevación sin polea 	 <ul style="list-style-type: none"> • enkel inschering met hijsblok • simple mouflage avec moufle • 2 fall reeving with houstingblock • 2 Fach Einsicherung mit Hakenflasche • passaggio semplice con paranca • solamente elevación con polea 	 <ul style="list-style-type: none"> • dubbel inschering • double mouflage • 4 fall reeving • 4 Fach Einsicherung • passaggio doppio • elevación doble 				

Konform richtlijn 2000/14/EG betreffende geluidsemissie van materieel voor gebruik buitenshuis en wijzigingen. - également conforme aux dispositions de la directive "émission sonores des équipements utilisés à l'extérieur des bâtiments" 2000/14/CE et aux législations la transposant. - Requirements of directive 2000/14/CE "noise emission in the environment by equipment for use outdoors, as amended. - Bestimmung der Richtlinie "Lärmübertragung des ausserhalb der Gebäude benutzten Ausrüstungen" 2000/14/EG und den gesetzlichen Vorschriften.



ARCOMET

Industrieweg 139 - 3583 Paal-Beringen - BELGIUM - T +32 (0)11 450 950 - EMAIL arcomet@arcomet.com - www.arcomet.com