



LASTENTABEL - COURBES DE CHARGES - LOAD CURVES - LASTKURVEN - CURVE DI CARICO - CURVAS DE CARGAS

m	3,50 - 11,55	12	14	16	18	20	22	24	26	28	30
kg	4000	3809	3137	2655	2293	2010	1784	1598	1444	1312	1200
ft	11'6" - 37'11"	39'4"	45'11"	52'6"	59'1"	65'7"	72'2"	78'9"	85'4"	91'10"	98'5"
lbs	8820	8400	6920	5850	5060	4430	3930	3520	3180	2890	2650

m	3,50 - 11,90	12	14	16	18	20	22	24	26	27,5
kg	4000	3953	3257	2758	2383	2090	1856	1664	1504	1375
ft	11'6" - 39'0"	39'4"	45'11"	52'6"	59'1"	65'7"	72'2"	78'9"	85'4"	90'3"
lbs	8820	8720	7180	6080	5250	4610	4090	3670	3320	3030

m	3,50 - 12,60	14	16	18	20	22	24	25
kg	4000	3523	2987	2583	2269	2016	1810	1720
ft	11'6" - 41'4"	45'11"	52'6"	59'1"	65'7"	72'2"	78'9"	82'0"
lbs	8820	7770	6590	5690	5000	4440	3990	3790

m	3,50 - 13,20	14	16	18	20	22,5
kg	4000	3725	3160	2735	2404	2080
ft	11'6" - 43'4"	45'11"	52'6"	59'1"	65'7"	73'10"
lbs	8820	8210	6970	6030	5300	4590

m	3,50 - 13,60	14	16	18	20
kg	4000	3869	3284	2843	2500
ft	11'6" - 44'7"	45'11"	52'6"	59'1"	65'7"
lbs	8820	8530	7240	6270	5510

m	3,50 - 14,30	16	17,50
kg	4000	3513	3150
ft	11'6" - 46'11"	52'6"	57'5"
lbs	8820	7750	6940

HOEKDRUKKEN - RÉACTIONS - REACTIONS - ECKDRÜCKE - REAZIONI - REACCIONES



	kN	225
	kips	51



	kN	175
	kips	39



kg	13 800
lbs	30 420

AANDRIJVINGEN - MÉCHANISMES - MECHANISMS - ANTRIEBE - MECCANISMI - MECANISMOS



max. 2000 kg

m/min	5,0	22,5	45,0
kg	2000	2000	1200
fpm	16	74	148
lbs	4400	4400	2650
kW	2,4	11,0	11,0
HP	~3,2	~14,7	~14,7



max. 4000 kg

m/min	2,5	11,3	22,5
kg	4000	4000	2000
fpm	8	37	74
lbs	8820	8820	4400
kW	2,4	11,0	11,0
HP	~3,2	~14,7	~14,7

	m/min	20 / 40	1,5 kW
	fpm	~66 / 131	~2 HP
	tr/min	0 - 1	2,6 kW
			~3,5 HP

	m/min	20 / 40	1,5 kW
	fpm	~66 / 131	~2 HP
	tr/min	0 - 1	2,6 kW
			~3,5 HP

	25
--	----





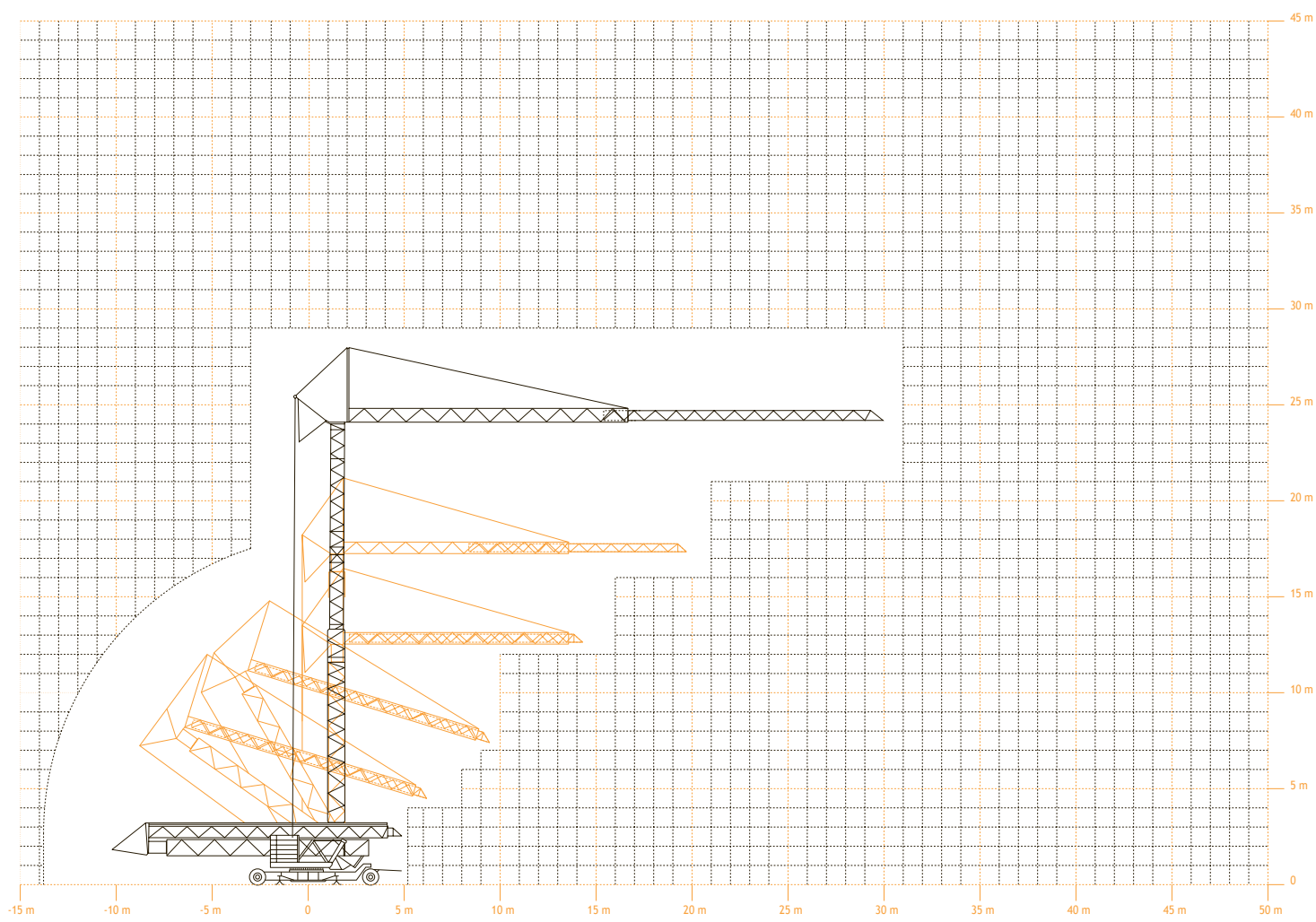



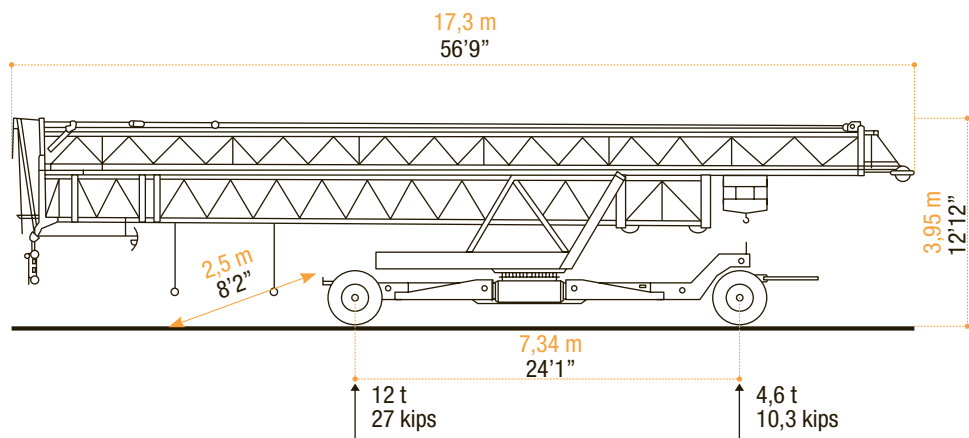







	220 - 380 V / 50 Hz
--	---------------------

VEREISTE MONTAGERUIMTE - ENCOMBREMENT AU MONTAGE - SPACE REQUIREMENT - ABMESSUNGEN - SPAZIO NECESSARIO PER IL MONTAGGIO



TRANSPORT



 <ul style="list-style-type: none"> • in bedrijf • en service • in service • in Betrieb • in servizio • en servicio 	 <ul style="list-style-type: none"> • buiten bedrijf • hors service • out of service • außer Betrieb • fuori servizio • fuera de servicio 	 <ul style="list-style-type: none"> • hijsen • levage • hoisting • heben • sollevamento • elevación 	 <ul style="list-style-type: none"> • loopkatriden • chariotage • jib trolleying • Katzfahren • traslazione carrello • poleas móviles 	 <ul style="list-style-type: none"> • zwenken • orientation • slewing • Schwenken • rotazione • orientación 	 <ul style="list-style-type: none"> • spanning • tension • voltage • spannung • tensione • tensión 	 <ul style="list-style-type: none"> • gewicht zonder ballast • poids propre sans lest • weight without ballast • gewicht ohne Ballast • peso senza zavorra • peso sin lastre
 <ul style="list-style-type: none"> • lengte • longueur • length • länge • lunghezza • longitud 	 <ul style="list-style-type: none"> • spoor • translation • rail • Kranfahren • carreggiata • rail 	 <ul style="list-style-type: none"> • vermogen • puissance • power • leistung • potenza • potencia 	 <ul style="list-style-type: none"> • micro snelheid • vitesse • speed • Geschwindigkeit • velocità • velocidad 	 <ul style="list-style-type: none"> • 2^e snelheid • 2^e vitesse • 2^e speed • 2^e Geschwindigkeit • 2^a velocità • 2^a velocidad 	 <ul style="list-style-type: none"> • 3^e snelheid • 3^e vitesse • 3^e speed • 3^e Geschwindigkeit • 3^a velocità • 3^a velocidad 	 <ul style="list-style-type: none"> • maximale hoekdruk • réactions • reactions • Eckdrücke : 10 kN = 1t • press. angolare massima • presión angular máxima
 <ul style="list-style-type: none"> • enkel inschering zonder hijsblok • simple mouflage sans moufle • 2 fall reeving without houstingblock • 2 Fach Einsicherung ohne Hakenflasche • passaggio semplice senza paranca • solamente elevación sin polea 	 <ul style="list-style-type: none"> • enkel inschering met hijsblok • simple mouflage avec moufle • 2 fall reeving with houstingblock • 2 Fach Einsicherung mit Hakenflasche • passaggio semplice con paranca • solamente elevación con polea 	 <ul style="list-style-type: none"> • dubbel inschering • double mouflage • 4 fall reeving • 4 Fach Einsicherung • passaggio doppio • elevación doble 				

Konform richtlijn 2000/14/EG betreffende geluidsemissie van materieel voor gebruik buitenshuis en wijzigingen. - également conforme aux dispositions de la directive "émission sonores des équipements utilisés à l'extérieur des bâtiments" 2000/14/CE et aux législations la transposant. - Requirements of directive 2000/14/CE "noise emission in the environment by equipment for use outdoors, as amended. - Bestimmung der Richtlinie "Lärmübertragung des ausserhalb der Gebäude benutzten Ausrüstungen" 2000/14/EG und den gesetzlichen Vorschriften.



ARCOMET

Industrieweg 139 - 3583 Paal-Beringen - BELGIUM - T +32 (0)11 450 950 - EMAIL arcomet@arcomet.com - www.arcomet.com